



# MONITORING REPORT

## CARBON OFFSET UNIT (CoU) PROJECT



**Title** : 1.2 MW Small Scale Hydro Power Project by M/s Flowgen  
Renewable Energy Pvt. Ltd.

**Version** : 1.0

**MR Date** : 27/01/2023

**CoU Issuance Period** : 02 Years

**Monitoring  
Duration** : 11/01/2021 to 31/12/2022



**Monitoring Report (MR)**  
**CARBON OFFSET UNIT (CoU) PROJECT**

**BASIC INFORMATION**

<b>Title of the project activity</b>	1.2 MW Small Scale Hydro Power Project By M/s Flowgen Renewable Energy Pvt. Ltd..
<b>UCR Project Registration Number</b>	268
<b>Scale of the project activity</b>	Small Scale
<b>Completion date of the MR</b>	27/01/2023
<b>Project participants</b>	Creduce Technologies Private Limited (Project Aggregator) M/s Flowgen Renewable Energy Pvt. Ltd. (Project Owner)
<b>Host Party</b>	India
<b>Applied methodologies and standardized baselines</b>	Applied Baseline Methodology: AMS-I. D: “Grid connected renewable electricity generation”, version 18 Standardized Methodology: Not Applicable.
<b>Sectoral scopes</b>	01 Energy industries (Renewable/Non-Renewable Sources)
<b>Estimated amount of GHG emission reductions for this monitoring period</b>	2021 : 3,680 CoUs (3,680 tCO <sub>2</sub> e) 2022 : 3,995 CoUs (3,995 tCO <sub>2</sub> e)
<b>Total:</b>	7,675 CoUs (7,675 tCO <sub>2</sub> e)

## **SECTION - A - Description of project activity**

### **A.1 Purpose and General description of Carbon offset Unit (CoU) project activity**

The proposed project titled under UCR is “1.2 MW Small Scale Hydro Power Project by M/s Flowgen Renewable Energy Pvt. Ltd.”, which is a hydroelectric power project located in Suma Ropa village, Kullu district in the state of Himachal Pradesh (India). The project is an operational activity with continuous reduction of GHG, currently being applied under “Universal Carbon Registry” (UCR).

#### **A.1.1 Purpose of the project activity:**

The project activity aims to harness kinetic energy of river water (renewable source) to generate electricity. The net generated electricity from the project activity is sold to state electricity board i.e., Himachal Pradesh State Electricity Board Ltd. (HPSEBL) under the Power Purchase Agreement (PPA) signed between the Project Proponent (PP) and the utility. In pre-project scenario, electricity delivered to the grid by the project activity would have otherwise been generated by the operation of fossil fuel-based grid-connected power plants and by the addition of new fossil fuel-based generation sources in the grid. Currently, NEWNE grid is connected to large numbers of fossil fuel-based power plants. Hence, project activity is displacing the gross electricity generation i.e., 8,528 MWh from the NEWNE grid. The project activity doesn't involve any GHG emission sources. The annual and the total CO<sub>2</sub>e emission reduction by the project activity over the defined monitoring period is as per Annexure I.

#### **A.1.2 Description of the installed technology and equipment:**

The project activity is a renewable power generation activity that incorporates the installation and operation of one hydro turbines, having its total installed capacity of 1.2 MW in the district Kullu of the state of Himachal Pradesh in India. This project has been promoted by M/s Flowgen Renewable Energy Pvt. Ltd. This Project activity is also called as Jail small hydroelectric power project.

The hydroelectric turbine was commissioned by the Himachal Pradesh State Electricity Board Ltd., (HPSEBL), Government of Himachal Pradesh, India on 11/01/2021.

Jail Small Hydropower Project has been contemplated as Run-of –River scheme on Jail Nallah a tributary of the Parbati river in Kullu Sub-division of Kullu district Himachal Pradesh. The stream originated from an altitude of 3519 meters. The catchment area of Jail Small Hydro Project above the proposed weir site is 6.31 Sq. Km. The area on both sides of the Stream is hilly with steep slopes. For diversion of jail nallah inflows, trench weir is proposed at El ± 2050 m. The size of weir has been proposed as 10 m long and 5.0 m wide to draw a design discharge of 0.37cumecs. The project activity aims to harness kinetic energy of water (renewable source) to generate electricity. The project comprises a trench weir which diverts the water into an intake placed on the right bank of the river. The diverted water passes through Desilting basin. Desilted water enters into water conductor system, forebay and the steel pressure shaft. A surface powerhouse is suitably located on a terrace at right bank of the river. The net head generated was 385.60 m. Tail water from the powerhouse is discharged back into the nallah. Below is the general description of different components of a hydro power plant:

**1. Diversion structure (trench weir):** A diversion structure is required across the Nallah for

diverting its water for power generation. The Nallah bed consists of pebbles, gravels and boulders.

2. **Intake/Power Channel:** The water fed from Desilting tank is led to tunnel inlet portal through a Rectangular R.C.C channel also known as Intake or Power Channel.
3. **Desilting Tank:** A Desilting chamber is considered necessary to remove silt particles to minimize the abrasion effects on the turbine runners.
4. **Penstock:** Water from Forebay is being taken to the Powerhouse to run hydraulic turbine through pressurized penstock pipe running from Forebay tank.
5. **Power House Building:** Power house building is a simple structure housing the generating units, auxiliary equipment, control panels and suitable outlet for tail water discharge.
6. **Tail Race Channel:** Turbine discharge shall be disposed to river through the separate tailrace channel.

#### **A.1.3 Relevant dates for the project activity (e.g., construction, commissioning, continued operation periods, etc.)**

The duration of the crediting period corresponding to the monitoring period is covered in this monitoring report.

UCR Project ID : 268  
 Start Date of Crediting Period : 11/01/2021  
 The project was commissioned : 11/01/2021  
 on

#### **A.1.4 Total GHG emission reductions achieved or net anthropogenic GHG removals by sinks achieved in this monitoring period**

The total GHG emission reductions achieved in this monitoring period is as follows:

<b>Summary of the Project Activity and ERs Generated for the Monitoring Period</b>	
Start date of this Monitoring Period	11/01/2021
Carbon credits claimed up to	31/12/2022
Total ERs generated (tCO <sub>2</sub> e)	7,675 tCO <sub>2</sub> e
Leakage Emission	0
Project Emission	0

#### **A.1.5 Baseline Scenario**

As per the approved consolidated methodology AMS-I.D. Version 18, if the project activity is the installation of a new grid-connected renewable power plant/unit, the baseline scenario is the following: **“The baseline scenario is that the electricity delivered to the grid by the project activity would have otherwise, been generated by the operation of grid-connected power plants and by the addition of new generation sources into the grid”.**

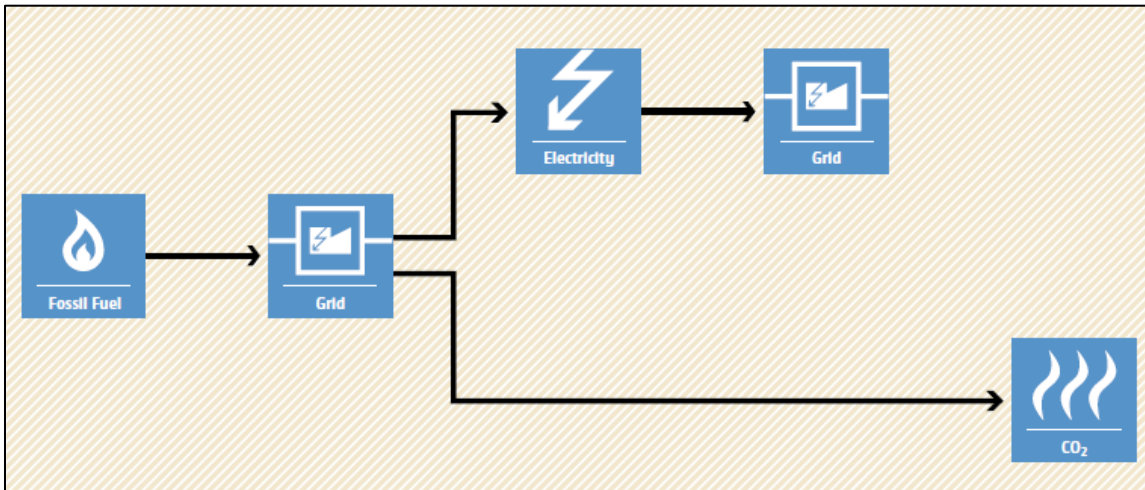

**Figure 1 Baseline Scenario**

## A.2 Location of Project Activity

Country	:	India
State	:	Himachal Pradesh
District	:	Kullu
Tehsil	:	Bhunter
Village	:	Suma ropa

Jail small hydropower project is accessed via Kullu-Manikaran Road. Powerhouse is proposed on jail stream near to Kasol Village on left bank of Jail Nallaha. The road from Jail onwards approaches all the proposed components of the Project. The nearest railway station is at broad-gauge at Kirtpur, Nearest airport is at Kullu. The geographic co-ordinate of the project locations is

Latitude : 32°00'20.8"N

Longitude : 77°17'24.6"E

The representative location map is shown below:

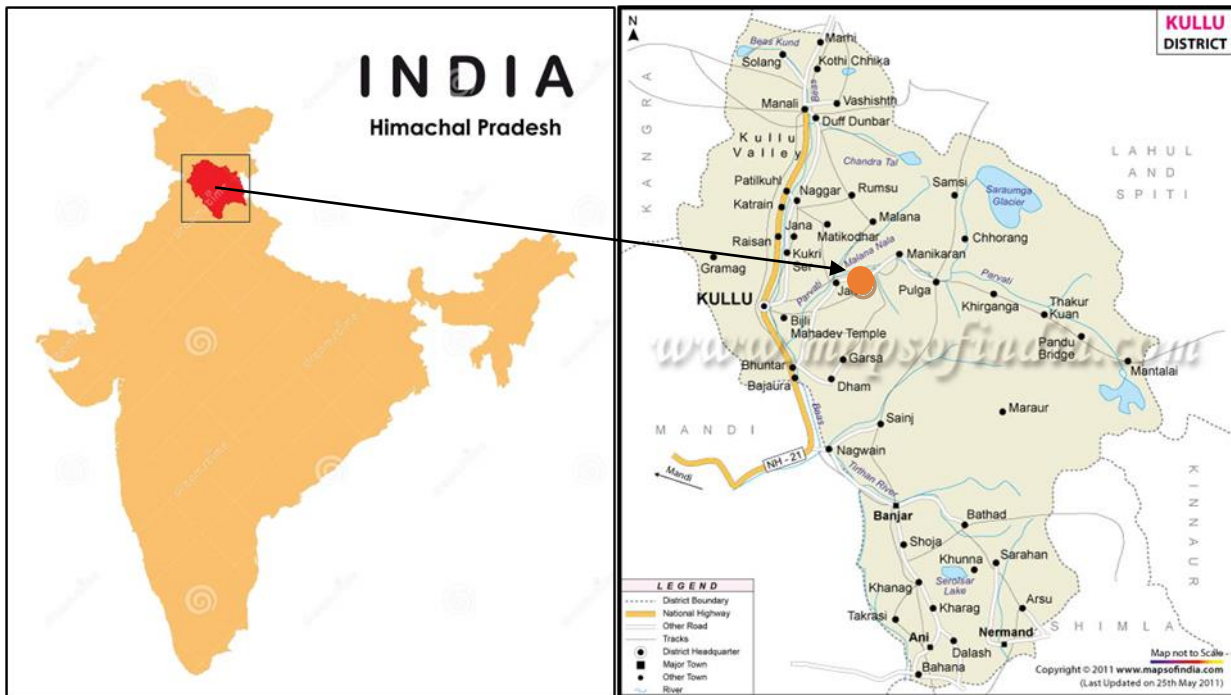

Figure-1- Location of the project activity (courtesy: google images and [www.mapsofindia.com](http://www.mapsofindia.com))

### A.3 Parties and project participants

Party (Host)	Participants
India	<p><b>Creduce Technologies Private Limited (Project Aggregator)</b>  <b>Contact person</b> : Shailendra Singh Rao  <b>Mobile</b> : +91 9016850742, 9601378723  <b>Address</b> : 2-O-13,14 Housing Board Colony, Banswara, Rajasthan -327001, India</p> <p><b>M/s Flowgen Renewable Energy Pvt. Ltd. (Project Owner)</b>  <b>Address:</b> 137, Pritam Nagar, Tehsil-Battiyata, District- Kangra, Himachal Pradesh-176001</p>

### A.4 Methodologies and standardized baselines

- Sectoral Scope : 01 Energy industries (Renewable/Non-Renewable Sources)
- Type : Renewable energy projects
- Category : AMS-I. D: “Grid connected renewable electricity generation”, Version 18

## **A.5 Crediting period of project activity**

Start date of the crediting period: 11/01/2021

Crediting period corresponding to this monitoring period: 11/01/2021 to 31/12/2022 (Both dates are inclusive)

## **A.6 Contact information of responsible persons/entities**

**Contact person** : **Shailendra Singh Rao**  
**Mobile** : +91 9016850742, 9601378723  
**Address** : 2-O-13,14 Housing Board Colony,  
Banswara, Rajasthan -327001, India

## SECTION - B - Implementation of project activity

### B.1 Description of implemented registered project activity

#### B.1.1 Provide information on the implementation status of the project activity during this monitoring period in accordance with UCR PCN

The project consists of a single hydro turbine having an installed capacity of 1200 kW which was commissioned on 11/01/2021 at Suma ropa village of District Kullu, Himachal Pradesh. M/s Flowgen Renewable Energy Pvt. Ltd. is the owner of this project. The project generates clean energy by utilizing the kinetic energy of flowing water from Jail Nallah a tributary of river Parbati in Kullu district.

#### B.1.2 For the description of the installed technology, technical process, and equipment, include diagrams, where appropriate

The project activity involves a single horizontal Pelton turbine (1200 kW) with internal electrical lines connecting the project activity with a local evacuation facility. The generators generate power at 3.3 kV, which can further be stepped up to 33 kV. The project activity operates at a frequency of 50 Hz and a voltage of 3.3 kV  $\pm 10\%$ . The average life of the generator is around 35 years as per the equipment supplier specification. The other salient features of the technology are:

Design Discharge	0.37 cumecs
Gross Head	408.470 m
Net Head	385.60 m
Diversion Weir	
Type	Trench weir
Shape	Rectangular
Length	20 m
Turbine Type	Horizontal Pelton
Speed of turbine	750 rpm
Step-up Transformer	2 NO, 3.3/33 kV 800 KVA each, 3 phase
Generators	Synchronous
Excitation System	(SESR) Self Excited Self-Regulated Brushless
Tail Race	Rectangular
Size	0.70 m x 0.70 m including 0.18 m freeboard, $\pm 12$ m Length
Number	2 No. Joining into one
Bed Slope	1 in 250 m
EL at end	1639.952 m
Penstock	
Dia at main	430 mm
Dia at Bifurcation	300 mm
Length	1245 m
Number	One penstock bifurcated into two near power house
Plate Thickness	8 mm to 12 mm
Velocity	3.06 m/sec
Dia at Bell Mouth	0.650 m
Design Flood	51.76 Cums
Maximum Observed Discharge	2.31 cums

Total Catchment area	6.31 sq kms
Type of Catchment	Snow fed and Rain fed
Peak	3519 m
D tank	20 m x 4.0 m (1.49 m depth at start and 1.78m depth at end including 0.50 m freeboard and hopper depth)
Flow through velocity	0.15 m/sec
Width of drain	0.30 m
Forebay Size	5.0 m x 4.0 m x 5.0 m including 0.50 m free board

## B.2 Do no harm or impact test of the project activity

There was no harm identified from the project and hence no mitigations measures are applicable.

Rational: as per ‘Central Pollution Control Board (Ministry of Environment & Forests, Govt. of India)’, final document on revised classification of Industrial Sectors under Red, Orange, Green and White Categories (07/03/2016), it has been declared that hydro project activity falls under the “White category”. White Category projects/industries do not require any Environmental Clearance such as ‘Consent to Operate’ from PCB as such project does not lead to any negative environmental impacts. Additionally, as per Indian Regulation, Environmental and Social Impact Assessment is not required for hydro Projects.



The Government of India has stipulated the following indicators for sustainable development in the interim approval guidelines for such projects which are contributing to GHG mitigations. The Ministry of Environment, Forests & Climate Change, has stipulated economic, social, environmental, and technological well-being as the four indicators of sustainable development. It has been envisaged that the project shall contribute to sustainable development using the following ways:

**Social well-being:** The project would help in generating direct and indirect employment benefits accruing out of ancillary units for project equipment’s and hydro turbines and for maintenance during the operation of the project activity. It will lead to the development of infrastructure around the project area in terms of improved road network etc. and will also directly contribute to the development of renewable infrastructure in the region.

**Economic well-being:** The project is a clean technology investment decision based on carbon revenue support, which signifies the flow of clean energy investments into the host country. The project activity requires temporary and permanent, skilled and semi-skilled manpower at the project location; this will create additional employment opportunities in the region. The generated electricity will be displacing an equivalent amount of electricity that otherwise would have been generated by fossil fuel sources, thereby reducing grid emission. In addition, improvement in infrastructure will provide new opportunities for industries and economic activities to be set up in the area. Apart from getting better employment opportunities, the local people will get better prices for their land, thereby resulting in overall economic development.

**Technological well-being:** The project activity employs state of art technology hydro turbines which has high power generation potential. The successful operation of project activity would lead to the promotion of this technology and would further push R&D efforts by technology providers to develop more efficient and better machinery in the future. Hence, the project leads to technological well-being.

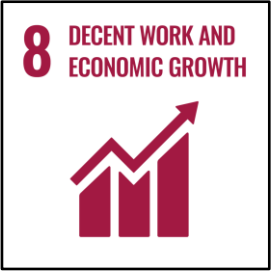
**Environmental well-being:** The project activity will generate power using zero emissions hydro-based power generation facility which helps to reduce GHG emissions and specific pollutants like SO<sub>x</sub>, NO<sub>x</sub>, and SPM associated with the conventional thermal power generation facilities. The project utilizes the kinetic energy of flowing water for generating electricity which is a clean source of energy. The project activity will not generate any air pollution, water pollution, or solid waste to the environment which otherwise would have been generated through fossil fuels. Thus, the project causes no negative impact on the surrounding environment contributing to environmental well-being.

SDG Goals	Description
<p data-bbox="256 591 344 622">Goal 7</p> 	<ul style="list-style-type: none"> <li data-bbox="483 573 1461 719">➤ The project has generated 8,528 MWh of clean energy, which with increased shared will increase the affordability at a cheaper rate to end users.</li> <li data-bbox="483 734 1461 936">➤ The project activity will utilize hydro energy (renewal resource) to generate power. The project activity will increase the share of renewable resource-based electricity to the global mix of energy consumption.</li> </ul>
<p data-bbox="256 978 344 1010">Goal 8</p> 	<ul style="list-style-type: none"> <li data-bbox="483 983 995 1014">➤ Decent work and economic growth.</li> <li data-bbox="483 1055 1461 1308">➤ This project activity generates additional employment for skilled and unskilled, also the project situated in a remote area will provide employment opportunities to unskilled people from villages. Training on various aspect including safety, operational issues and developing skill sets will also be provided to employees.</li> </ul>
<p data-bbox="240 1373 344 1404">Goal 13</p> 	<ul style="list-style-type: none"> <li data-bbox="483 1377 1461 1464">➤ This 1.2 MW hydro project meets the SDG 13 goal by saving fossil fuel and producing clean energy.</li> <li data-bbox="483 1505 1461 1592">➤ This project has avoided 7,675 tons of CO<sub>2</sub> emissions during this monitoring period.</li> <li data-bbox="483 1632 1350 1664">➤ <b>SDG 13</b> on clean energy is closely related and complementary.</li> <li data-bbox="483 1704 1461 2024">➤ In a greenfield project, electricity delivered to the grid by the project would have otherwise been generated by the operation of grid-connected power plants. Thereby the project activity reduces the dependence on fossil fuel-based generation units and as there are no associated emissions with this project it contributes to the reduction of greenhouse gases (GHG) emissions.</li> </ul>

### B.3 Baseline Emissions

The baseline scenario identified at the MR stage of the project activity is:

In the absence of the project activity, the equivalent amount of electricity would have been imported from the grid (which is connected to the unified Indian Grid system (NEWNE Grid)), which is carbon intensive due to being predominantly sourced from fossil fuel-based power plants. Hence, the baseline scenario of the project activity is the grid-based electricity system, which is also the pre-project scenario.

Schematic diagram showing the baseline scenario:

#### Baseline Scenario:

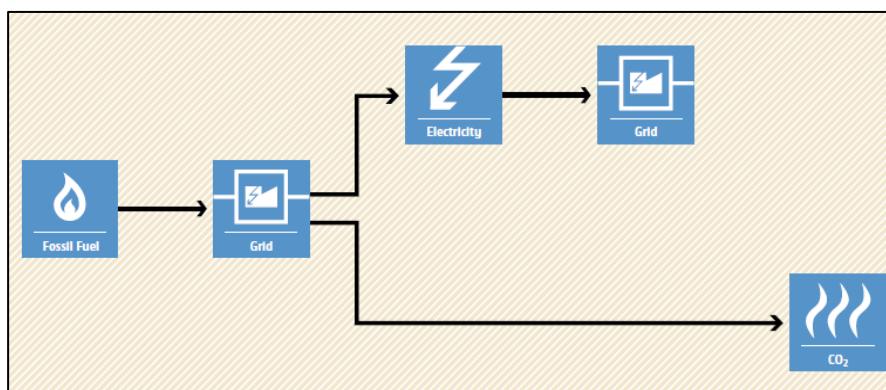

#### Project Scenario:

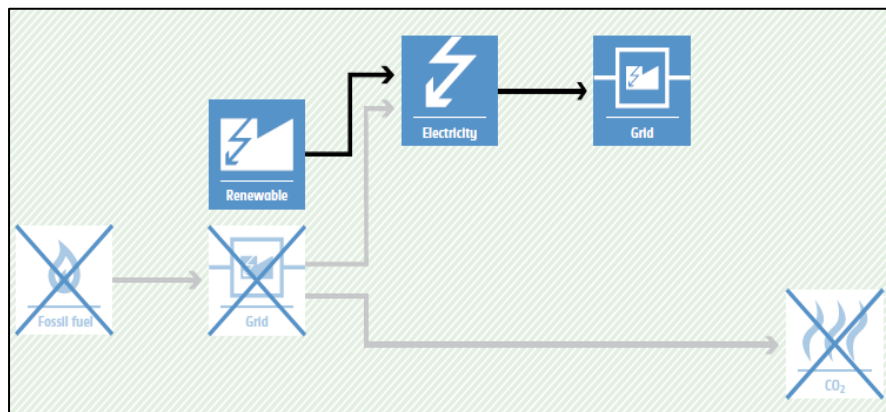

Thus, this project activity was a voluntary investment that replaced an equivalent amount of electricity from the Indian grid. The project proponent was not bound to incur this investment as it was not mandatory by national and sectoral policies. Thus, the continued operation of the project activity would continue to replace fossil fuel-based power plants and fight against the impacts of climate change. The Project Proponent hopes that carbon revenues from carbon credits will help repay the loans and help in the continued maintenance of this project activity.

### B.4 De-bundling

This project activity is not bundled component of a larger project activity.

## SECTION - C - Application of methodologies and standardized baselines

### C.1 References to methodologies and standardized baselines

<b>Sectoral scope</b>	:	01, Energy industries (Renewable/Non-renewable sources)
<b>Type</b>	:	I-Renewable energy projects
<b>Category</b>	:	AMS. I.D. (Title: “Grid connected renewable electricity generation”, version 18)

### C.2 Applicability of methodologies and standardized baselines

The project activity involves the generation of grid-connected electricity from the construction and operation of a new hydro power-based power project. The project activity has an installed capacity of 1.2 MW which will qualify for a small-scale project activity under Type-I of the small-scale methodology. The project status is corresponding to the methodology AMS-I.D., version 18, and the applicability of the methodology is discussed below:

Applicability Criterion	Project Case
1. This methodology comprises renewable energy generation units, such as photovoltaic, hydro, tidal/wave, wind, geothermal and renewable biomass: (a) Supplying electricity to a national or a regional grid; or (b) Supplying electricity to an identified consumer facility via national/regional grid through a contractual arrangement such as wheeling.	The project activity is a Renewable Energy Project i.e., hydropower project which falls under applicability criteria option 1 (a) i.e., “Supplying electricity to a national or a regional grid”
2. This methodology is applicable to project activities that: (a) Install a greenfield plant; (b) Involve a capacity addition in (an) existing plant(s); (c) Involve a retrofit of (an) existing plant(s); (d) Involve a rehabilitation of (an) existing plant(s)/unit(s); or (e) Involve a replacement of (an) existing plant(s).	Option (a) of applicability criteria 2 is applicable as the project is a greenfield plant  /Unit. Hence the project activity meets the given applicability criterion.

<p>3. Hydro power plants with reservoirs that satisfy at least one of the following conditions are eligible to apply this methodology:</p> <p>a) The project activity is implemented in the existing reservoir, with no change in the volume of the reservoir; or</p> <p>b) The project activity is implemented in the existing reservoir, where the volume of the reservoir(s) is increased and the power density as per definitions given in the project emissions section, is greater than 4 W/m<sup>2</sup>.</p> <p>c) The project activity results in new reservoirs and the power density of the power plant, as per definitions given in the project emissions section, is greater than 4 W/m<sup>2</sup></p>	<p>It is run of river type of project; hence, this criterion is not applicable.</p>
<p>4. If the new unit has both renewable and non-renewable components (e.g., a wind/diesel unit), the eligibility limit of 15 MW for a small-scale CDM project activity applies only to the renewable component. If the new unit co-fires fossil fuel, the capacity of the entire unit shall not exceed the limit of 15 MW.</p>	<p>The proposed project is a 1.2 MW hydropower project, i.e., only component is a renewable power project below 15MW, thus the criterion is not applicable to this project activity.</p>
<p>5. Combined heat and power (co-generation) systems are not eligible under this category.</p>	<p>The project is hydro power project and thus, the criterion is not applicable to this project activity.</p>
<p>6. In the case of project activities that involve the capacity addition of renewable energy generation units at an existing renewable power generation facility, the added capacity of the units added by the project should be lower than 15 MW and should be physically distinct from the existing units.</p>	<p>The proposed project is a greenfield 1.2 MW hydropower project, i.e., only component is renewable power project below 15 MW, thus the criterion is not applicable to this project activity.</p>
<p>7. In the case of retrofit, rehabilitation or replacement, to qualify as a small-scale project, the total output of the retrofitted, rehabilitated or replacement power plant/unit shall not exceed the limit of 15 MW.</p>	<p>The proposed project is a greenfield 1.2 MW hydropower project, i.e., only component is renewable power project below 15 MW, thus the criterion is not applicable to this project activity.</p>
<p>8. In the case of landfill gas, waste gas, wastewater treatment and agro-industries projects, recovered methane emissions are eligible under a relevant Type III category. If the recovered methane is used for electricity generation for supply to a grid, then the baseline for the electricity component shall be in</p>	<p>The proposed project is a greenfield 1.2 MW hydropower project; hence, this criterion is not applicable to this project activity.</p>

accordance with procedure prescribed under this methodology. If the recovered methane is used for heat generation or cogeneration other applicable Type-I methodologies such as “AMS-I.C.: Thermal energy production with or without electricity” shall be explored.	
9. In case biomass is sourced from dedicate plantations, the applicability criteria in the tool “Project emissions from cultivation of biomass” shall apply.	No biomass is involved, the project is only a hydro power project and thus the criterion is not applicable to this project activity.

### C.3 Applicability of double counting emission reductions

There is no double accounting of emission reductions in the project activity due to the following reasons:

- Project is uniquely identifiable based on its location coordinates,
- Project has a dedicated commissioning certificate and connection point,
- Project is associated with energy meters which are dedicated to the consumption point for the project developer.

### C.4 Project boundary, sources, and greenhouse gases (GHGs)

As per applicable methodology AMS-I.D. Version 18, “The spatial extent of the project boundary includes the project power plant and all power plants connected physically to the electricity system that the project power plant is connected to.”

Thus, the project boundary includes the hydropower plant and the Indian grid system.

Source		Gas	Included?	Justification/Explanation
Baseline	Grid connected electricity generation	CO <sub>2</sub>	Yes	Main emission source
		CH <sub>4</sub>	No	Minor emission source
		N <sub>2</sub> O	No	Minor emission source
		Other	No	No other GHG emissions were emitted from the project
Project	Greenfield hydroelectric	CO <sub>2</sub>	No	No CO <sub>2</sub> emissions are emitted from the project

Source		Gas	Included?	Justification/Explanation
	power project Activity	CH <sub>4</sub>	No	Project activity does not emit CH <sub>4</sub>
		N <sub>2</sub> O	No	Project activity does not emit N <sub>2</sub> O
		Other	No	No other emissions are emitted from the project

## C.5 Establishment and description of the baseline scenario

As per the approved consolidated methodology AMS-I.D. Version 18, if the project activity is the installation of a new grid-connected renewable power plant/unit, the baseline scenario is the following:

“The baseline scenario is that the electricity delivered to the grid by the project activity would have otherwise been generated by the operation of grid-connected power plants and by the addition of new generation sources into the grid”.

The project activity involves setting up a new hydropower plant to harness the kinetic energy of flowing water. In the absence of the project activity, the equivalent amount of power would have been supplied by the Indian grid, which is fed mainly by fossil fuel-fired plants. Hence, the baseline for the project activity is the equivalent amount of power produced at the Indian grid.

A "grid emission factor" refers to a CO<sub>2</sub> emission factor (tCO<sub>2</sub>/MWh) that will be associated with each unit of electricity provided by an electricity system. The UCR recommends an emission factor of 0.9 tCO<sub>2</sub>/MWh for the 2013 - 2020 years as a fairly conservative estimate for Indian projects not previously verified under any GHG program. Also, for the vintage 2021-2022, the combined margin emission factor calculated from the CEA database in India results in higher emissions than the default value. Hence, the same emission factor has been considered to calculate the emission reduction under a conservative approach.

### C.5.1 Net GHG Emission Reductions and Removals

$$\text{Thus, } ER_y = BE_y - PE_y - LE_y$$

Where:

$ER_y$  = Emission reductions in year y (tCO<sub>2</sub>/y)

$BE_y$  = Baseline Emissions in year y (t CO<sub>2</sub>/y)

$PE_y$  = Project emissions in year y (tCO<sub>2</sub>/y)

$LE_y$  = Leakage emissions in year y (tCO<sub>2</sub>/y)

- **Baseline Emissions**

Baseline emissions include only CO<sub>2</sub> emissions from electricity generation in power plants that are

displaced due to the project activity. The methodology assumes that all project electricity generation above baseline levels would have been generated by existing grid-connected power plants and the addition of new grid-connected power plants. The baseline emissions are to be calculated as follows:

$$BE_y = EG_{PJ,y} \times EF_{grid,y}$$

$BE_y$  = Baseline emissions in year y (t CO<sub>2</sub>)

$EG_{PJ,y}$  = Quantity of net electricity generation that is produced and fed into the grid as a result of the implementation of the CDM project activity in year y (MWh)

$EF_{grid,y}$  = UCR recommended emission factor of 0.9 tCO<sub>2</sub>/MWh has been considered.  
(Reference: General Project Eligibility Criteria and Guidance, UCR Standard, page 4)

Hence

Baseline Emissions Calculation				
Sr.No	Year	EGpy (MWh)	EF <sub>grid,y</sub>	BE <sub>y</sub>
1	2021	4089.13	0.9	3680
2	2022	4439.03	0.9	3995
3	BE (tCO <sub>2</sub> e) for the period of 2021 to 2022			7,675

Estimated annual baseline emission reductions (BE<sub>y</sub>)

$$= 8,528 \text{ MWh/year} \times 0.9 \text{ tCO}_2/\text{MWh}$$

$$= 7,675 \text{ tCO}_2/\text{year}$$

- **Project Emissions**

As per Paragraph 39 of AMS-I.D. version-18, only emissions associated with fossil fuel combustion, emissions from the operation of geothermal power plants due to the release of non-condensable gases, and emissions from a water reservoir of hydro should be accounted for the project emission. Since the project activity is a hydroelectric power project, project emission for renewable energy plants is nil.

**Thus, PE = 0**

- **Leakage Emission**

As per paragraph 42 of AMS-I.D. version-18, 'If the energy generating equipment is transferred from another activity, leakage is to be considered.' In the project activity, there is no transfer of energy-generating equipment and therefore the leakage from the project activity is considered zero.

**Hence, LE = 0**

The actual emission reduction achieved during the first CoU period shall be submitted as a part of the first monitoring and verification.

However, for the purpose of an ex-ante estimation, the following calculation has been submitted:

$$\text{Hence Net GHG emission reduction,} = 7,675 - 0 - 0 = 7,675 \text{ tCO}_2/\text{year (i.e., 7,675 CoUs/year)}$$

## C.6 Prior History

The project was not applied under any other GHG mechanism. Hence the project will not cause double accounting of carbon credits (i.e., CoUs).

## C.7 Changes to the start date of crediting

The crediting period under UCR has been considered from the date of the generation of electricity. There is no change in start date of crediting period.

## C.8 Permanent changes from MR monitoring plan, applied methodology or applied standardized baseline

Not applicable.

## C.9 Monitoring period number and duration

Total Monitoring Period: 02 Years

Date: 11/01/2021 to 31/12/2022 (inclusive of both dates).

## C.10 Monitoring Plan

### Data and Parameters available (ex-post values):

Data / Parameter	UCR recommended emission factor
Data unit	tCO <sub>2</sub> /MWh
Description	A "grid emission factor" refers to a CO <sub>2</sub> emission factor (tCO <sub>2</sub> /MWh) which will be associated with each unit of electricity provided by an electricity system. The UCR recommends an emission factor of 0.9 tCO <sub>2</sub> /MWh for the 2013 - 2020 years as a fairly conservative estimate for Indian projects not previously verified under any GHG program. Hence, the same emission factor has been considered to calculate the emission reduction under a conservative approach.
Source of data	<a href="https://cea.nic.in/wp-content/uploads/baseline/2023/01/Approved_report_emission__2021_22.pdf">https://cea.nic.in/wp-content/uploads/baseline/2023/01/Approved_report_emission__2021_22.pdf</a>
Value applied	0.9
Measurement methods and procedures	-
Monitoring frequency	Fixed parameter
Purpose of Data	For the calculation of the emission factor of the grid
Additional Comment	The combined margin emission factor as per CEA database (current version 18, December 2022) results into higher emission factor. Hence for 2022 vintage UCR default emission factor remains conservative.

**Data and Parameters to be monitored (ex-post monitoring values):**

Data / Parameter	$EG_{PJ, facility, y}$
Data unit	MWh
Description	Net electricity supplied to the NEWNE grid facility by the project activity during 11/01/2021 to 31/12/2022.
Source of data	Monthly electricity credit note provided by HPSEBL
Measurement procedures (if any):	Data Type: Measured Monitoring equipment: Energy Meters are used for monitoring Recording Frequency: Continuous monitoring and Monthly recording from Energy Meters, Summarized Annually Archiving Policy: Paper & Electronic Calibration frequency: 5 years (as per CEA provision)
Measurement Frequency:	Monthly
Value applied:	8,528 (Ex-post estimate)
QA/QC procedures applied:	Continuous monitoring, hourly measurement monthly recording. Tri-vector (TVM)/ABT energy meters with accuracy class 0.2s
Purpose of data:	The Data/Parameter is required to calculate the baseline emission.
Any comment:	Data will be archived electronically for a period of 36 months beyond the end of crediting period.

## ANNEXURE I (Emission Reduction Calculation)

<b>1.2 MW Small Scale Hydro Power project by M/s Flowgen Renewable Energy Pvt. Ltd.</b>												
<b>Month - Wise Energy Delivered to Grid (in kWh)</b>												
Year	Jan	Feb	Mar	Apr	May	Jun	Jul	Aug	Sep	Oct	Nov	Dec
2021	1,23,617	1,00,220	1,74,425	3,40,644	3,10,788	2,98,391	6,52,305	6,76,749	6,58,940	3,76,612	2,03,758	1,72,679
2022	1,82,457	1,88,917	5,46,672	2,96,645	2,26,281	1,69,187	5,93,989	7,77,144	6,02,195	4,53,087	2,28,726	1,73,727
<b>Year-Wise Emission reduction calculation for the project activity</b>												
Year	Total No. of Electricity delivered in kWh			Recommended emission factor tCO <sub>2</sub> /MWh				Total CoUs generated				
2021	4089128			0.9				3,680				
2022	4439027			0.9				3,995				
<b>Total CoUs to be issued for the first monitoring period (Year: 2021 to 2022)</b>												<b>7,675</b>